



WATER-LIFT

INFO

DEGREE OF PROTECTION:

IP 55

PATENT:

RM2010U000076

TECHNICAL SPECIFICATION OF THE MAIN COMPONENTS				
Vortex Pump (MONO version)				
Hydraulic performances:	Voltage	12 Vdc	24 Vdc	230 Vac
H: 4 mt— Q: 70 l/min	Wire Gauge Up to 5mt (<15feet)	10mm2 6 AWG	4mm2 11AWG	0.75mm2 18AWG
H: 1,5 mt— Q: 100 l/min	Wire Gauge Over to 5mt (>15feet)	13mm2 6 AWG	6mm2 9AWG	1mm2 17AWG
	Absorption	22 A	10 A	3 A

NOTE:

Data refers to the absorption at the height of 1.5mt.

Grey water transfer units work intermittently. The frequency of activation is proportional to flow and head of discharge. Therefore the effective power consumption in Ah may change.

ADD PROPER FUSE



FURTHER USEFUL DATA

CAPACITY OF MAIN APPLIANCES

Wash Basin\Bidet: 12 l/min (approximately, it depends on water pressure and type of faucet. With regards to faucets there is a specific

European Norm whom manufacturers comply with).

Shower: 12 l/min (see notes above).

Bath tub (drainage): 60 l/min.

Bath tub cm 170x70 – max capacity: 150 l (with no person in it).

ADVICES TO DESIGN THE HYDRAULIC SYSTEM:

1. Estimate how many units is advisable to install, considering the total capacity (increased by 30% for reliability reasons) of all appliances connected to it, as they could simultaneously discharge.

2. Ensure that in every possible conditions of navigation all connected appliances can easily discharge for gravity into the Pro-Lift tank without

any problem.

3. The predisposed discharge pipe must be as short and linear as possible, since, besides the height to be reached by water (head discharge),

also many 90° elbows, several fittings, and dimensions (40 mm) of the discharge pipe at the bottom of the Pro-Lift, slightly reduce the outlet

pump instantaneous capacity (l/min), due to their resistance to water flow that causes further losses of performances.

CONNECTIONS	
Hydraulic Connections	
Inlet	Hose with ID of 40 mm (3/4")
Outlet	Hose with ID of 40 mm (1/2")

DO NOT CLOSE THE TANK VENTILATION.
 IF PREFERRED, FIX TIGHTLY A TUBE
 TO THIS PIPE WITH A CLAMP TO ASSURE
 THE SEAL AND BRING IT TO THE OUTDOOR.
DO NOT USE FILTER (AS I.E. CARBON FILTER)
 THAT COULD REDUCE THE AIR PASSAGE.

FIX THE UNIT TO
 THE FLOOR WITH
 4 SCREWS (NOT
 SUPPLIED), TO BE
 INSERTED THROUGH
 THE RUBBER FEET

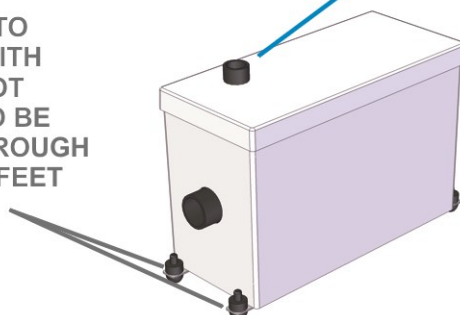

DIMENSIONS

MONO VERSION

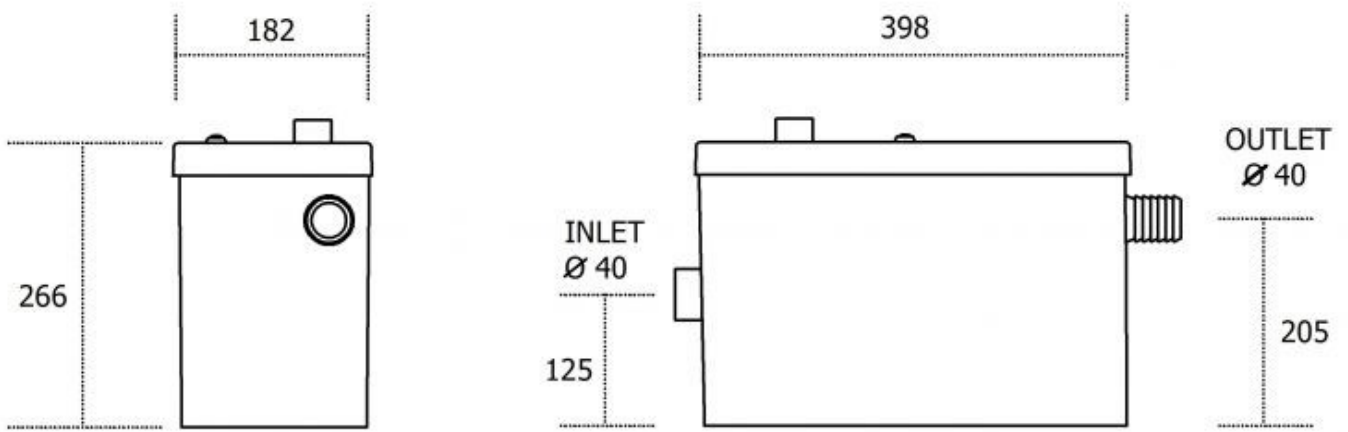

www.planus.eu

